

# SAA2415 Installation Instructions

www.ergomart.com | 888 420 3200

**1**

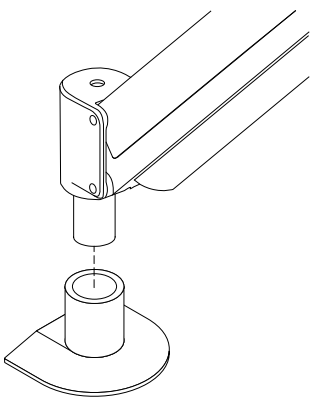

Insert arm pin into completely attached and assembled mount

**2**

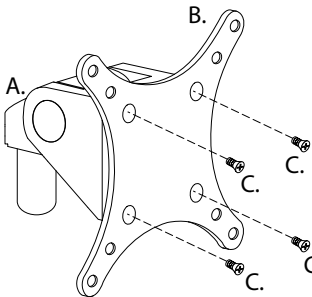

Attach correct VESA plate to tilter head

**3**

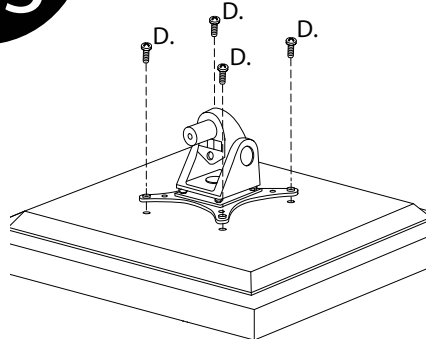

Attach tilter head/VESA plate to LCD

**4**

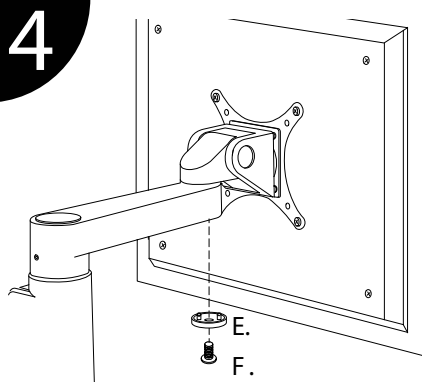

Slide tilter pin into the end of arm  
Secure with washer and screw  
PLEASE NOTE: See supplemental instructions provided if using the XHD Spring Tilter-head

**5**

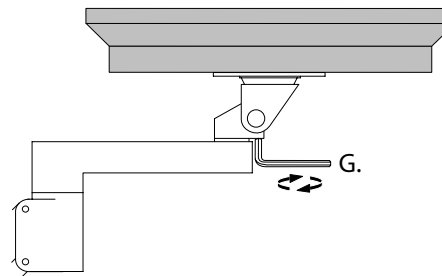

Adjust vertical tilt resistance on tilter head

**6**

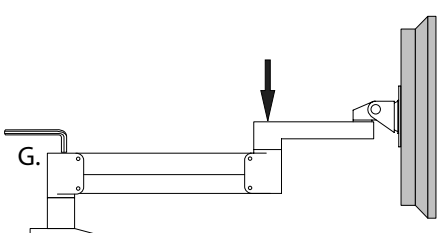

A) Push arm down to horizontal position  
B) Rotate wrench **CLOCKWISE** to weaken arm  
C) Once adjusted correctly arm should float LCD

**7**

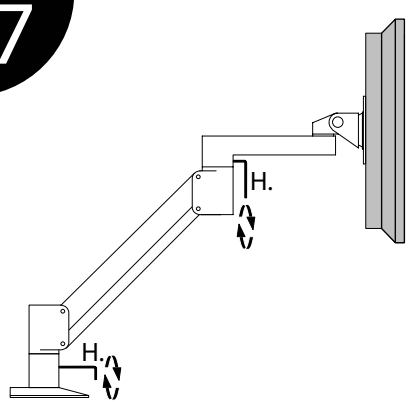

Increase resistance to rotation at articulation points by tightening small setscrews  
**DO NOT OVERTIGHTEN**

**8**

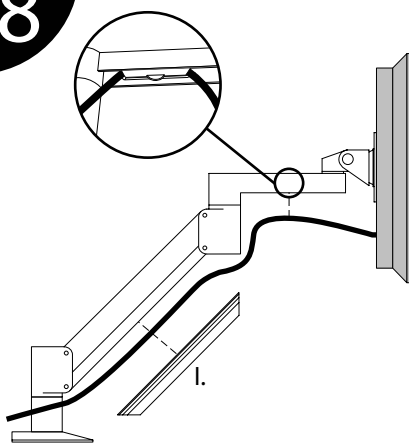

Please call Ergomart at  
**888 420 3200**  
with your questions

www.ergomart.com







## **ERGOMART**

Ergonomic solutions for office and light industrial work environments

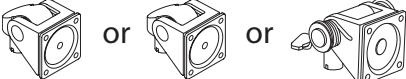
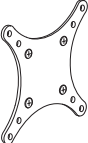
©2011 Ergomart. All rights reserved.

# SAA2415 Parts List

www.ergomart.com | 888 420 3200

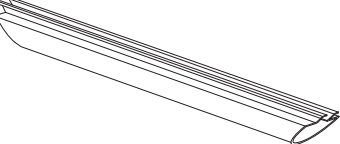
ITEM	DESCRIPTION / PART NO.	QUANTITY
A. 	Tilter Head / Spring Tilter / HD Spring Tilter	1
B. 	VESAs Adapter Plate	1
C. 	10-32 x 3/8" (9.525mm) Philips Flat Head Screw 701164	4
D. 	M4-12 Philips Pan Head Screw 702096	4
E. 	Dog Washer	1
F. 	Dog Washer Screw	1
G. 	1/4" Allen Wrench	1
H. 	3/32" (2.388mm) Allen Wrench 700146	1
I. 	Cable Cap 102043-9.5A	1

## **ERGOMART**

Ergonomic solutions for office and light industrial work environments

©2011 Ergomart. All rights reserved.