

PM40 LCD Pole Mount Installation Instructions

www.ergomart.com | 888 420 3200

1

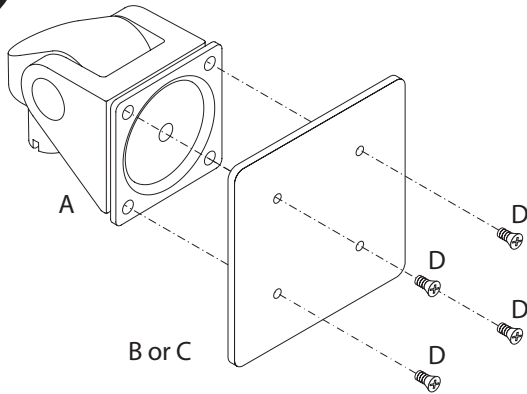

Attach B or C to tilthead.

2

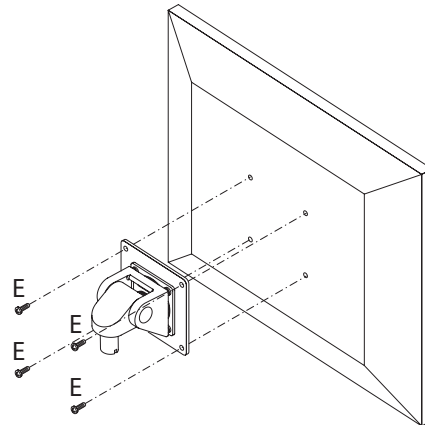

Attach monitor to VESA plate using phillips pan head screws.

3

Nominal Diameter of Pole	Bushing Insert
1.5"	(insert ribbed)
1.75"	(Insert smooth)
1.9"	Pre-installed Pad
2"	No Bushing Required

Use chart to select proper bushing for the poles diameter. Mount comes, with easy to remove pad insert, ready for 1.9 inch poles and Ergomart series 192 pole.

4

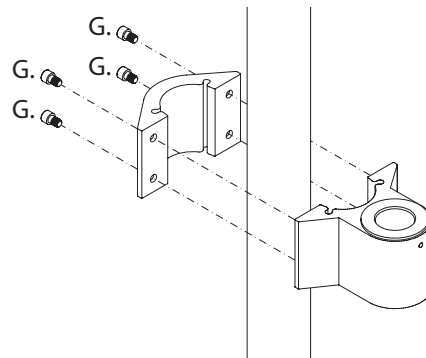

*Plastic bushing is used for poles with a 1-3/4" diameter only. With the proper bushing in place use the socket head screws to attach and secure the mount to the pole.

5

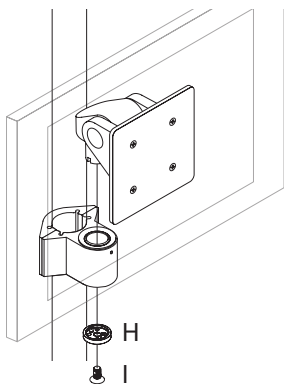

Place tilthead with monitor in mount and secure with dog washer and screw.

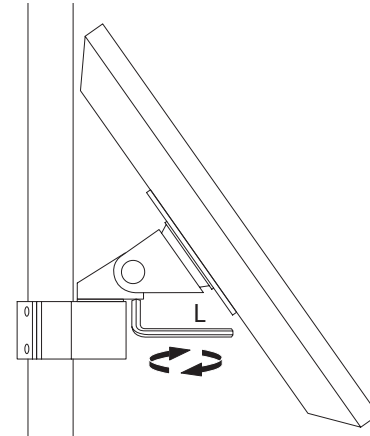







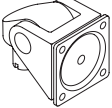
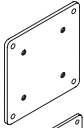
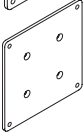

ERGOMART

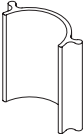
Ergonomic solutions for office and light industrial work environments

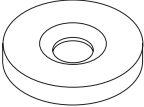
PM40 LCD Pole Mount Parts List

www.ergomart.com | 888 420 3200

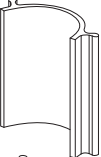
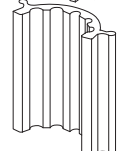
ITEM	DESCRIPTION / PART NO.	QUANTITY
A 	Sloped Tilter HD only	1
B 	75 mm VESA Adapter Plate VESA75	1
C 	100 mm VESA Adapter Plate VESA100	1
D 	10-32 x 3/8" Phillips Flat Head Screw 702281	1 (4-pack)
E 	M4-12 Phillips Pan Head Screw	4
F 	Bushing	2
G 	1/4-20 x 1/2" Screw	4
H 	Dog Washer	1
I 	10-32 x 3/8" FPhMS with Lock Patch	1
J 	7/32" Allen Wrench	1
K 	Foam Pad	1
L 	Smooth Insert	1
M 	Ribbed Insert	1

ERGOMART

Ergonomic solutions for office and light industrial work environments