

S1607 & S1614 Installation Instructions

www.ergomart.com | 888 420 3200

1

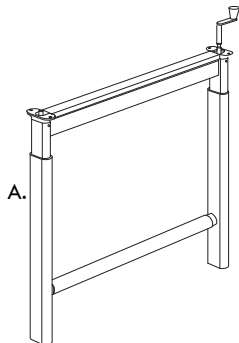

Note: Surfaces can have a hole on right, left or both sides. Assembly is easier with two people.

WARNING: H-stand MUST be cranked open two inches for installation (about ten full rotations.) Set crank aside for later use.

2

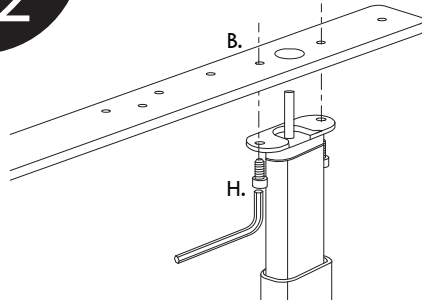

Attach the mounting brackets to the H-Stand using H and G.

3

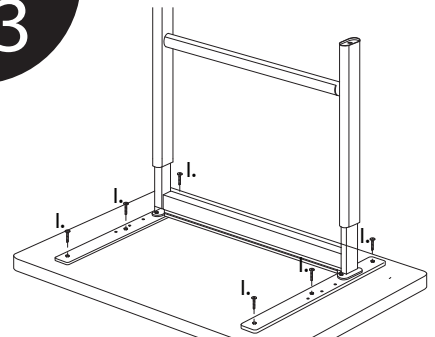

Attach the base to the worksurface using I.
Note: Surfaces come pre-drilled for multiple products. A standard six hole pattern for this base. For custom positioning 1/16" pilot holes are recommended.

4

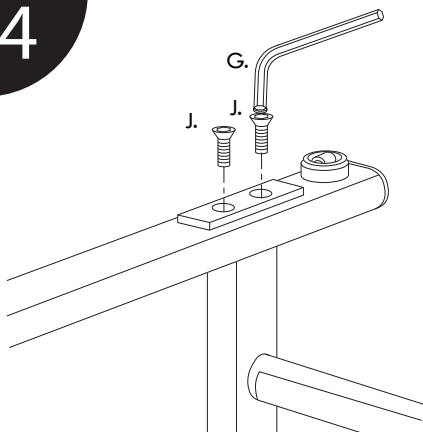

Use J and G to attach C and D to the base.

5

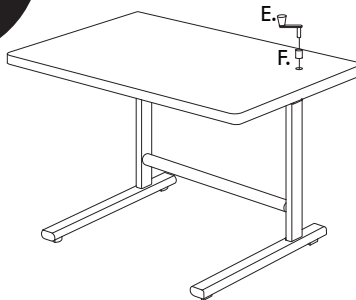

Stand the table upright. Insert F into the hole. Use E to adjust table height. K can be used to protect the hole from debris when not using the crank handle.

6

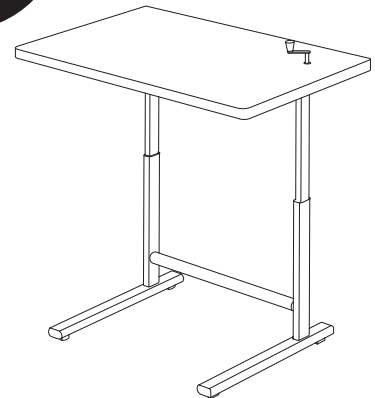

7

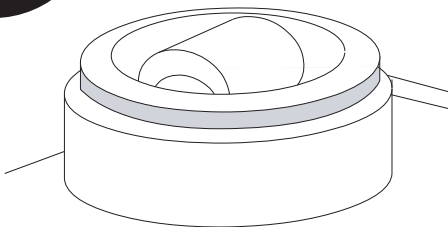

Close-up of Roller

Roller can be turned any direction with channel lock pliers by gripping the shaded surface and turning

Please call Ergomart at
888 420 3200
with your questions

www.ergomart.com







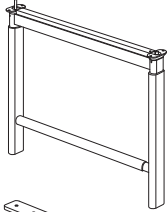
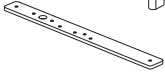
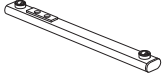
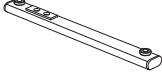

ERGOMART

Ergonomic solutions for office and light industrial work environments

©2009 Ergomart. All rights reserved.

S1607 & S1614 Parts List

www.ergomart.com | 888 420 3200

ITEM	DESCRIPTION / PART NO.	QUANTITY
A. 	H-Stand	1
B. 	Mounting Bracket	2
C. 	Foot with rollers	1
D. 	Foot with adjustable glider	1
E. 	Crank Handle	1
F. 	Bushing	1
G. 	5mm Hex Wrench	1
H. 	M6-1 Socket Head Cap screw	4
I. 	Phillips Pan Head #10-1 inch Screw	6
J. 	Flat Socket Head Cap Screw M8-1.25x25mm	4
K. 	Spacer	1

ERGOMART

Ergonomic solutions for office and light industrial work environments