

# SAA2321 LCD Arm Installation Instructions

www.ergomart.com | 888 420 3200

## Important Safety Instructions



### **Read and understand all these safety instructions before using the product.**

Do not mount the Desk Base of the Arm on an unstable surface or any surface that could not mount the Desk Base firmly.

For safety reasons, the internal gas-strut of the LCD Arm product was pre-adjusted in the factory to the lowest force to prevent the Arm body from being recoiled during installation.

During installation, beware of the recoil of the Arm body when attaching or detaching the LCD monitor to the Arm.

To prevent damage or injury when changing the LCD monitor, always readjust the gas-strut to the lowest force level to control the recoil of the Arm body when the LCD monitor is detached.

Do not attempt to disassemble, service or modify the product by yourself.





Use only a slightly damp cloth to clean the Arm surface. Never apply flammable solvents like alcohol, benzene, thinner, etc. to the product.





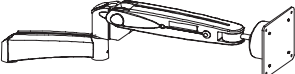

# **ERGOMART**

*Ergonomic solutions for office and light industrial work environments*

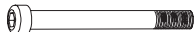
# SAA2321 LCD Arm Components & Fasteners

www.ergomart.com | 888 420 3200

Components	Description
A. 	Desk Base with Clamp
B. 	Arm Assembly
C. 	Plastic Cap
D. 	Base Cushion
E. 	U Bracket







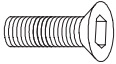

Fasteners	Description
a. 	Plastic Spacer
b. 	Round Head Cap Screw
c. 	Washer
d. 	Disc Spring Washer
e. 	M5 Hex Wrench
f. 	M8 Thread Rod
g. 	Wing Nut
h. 	M4 Hex Wrench

## **ERGOMART**

*Ergonomic solutions for office and light industrial work environments*

# SAA2321 LCD Arm Components & Fasteners

www.ergomart.com | 888 420 3200

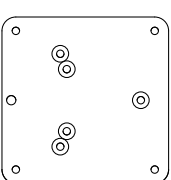
Fasteners	Description
i. 	M8 Flat Head Cap Screw
j. 	Round Head Cap Screw
k. 	M4 6mm Screw
l. 	M4 10mm Screw
m. 	Cable Tie
n. 	Cable Clip
o. 	M5 10mm Set Screw
p. 	M3 6mm Screw
q. 	75mm Vesa Plate

**ERGOMART**

*Ergonomic solutions for office and light industrial work environments*

# SAA2321 LCD Arm Assembly Instructions

www.ergomart.com | 888 420 3200

## Assembly Instructions

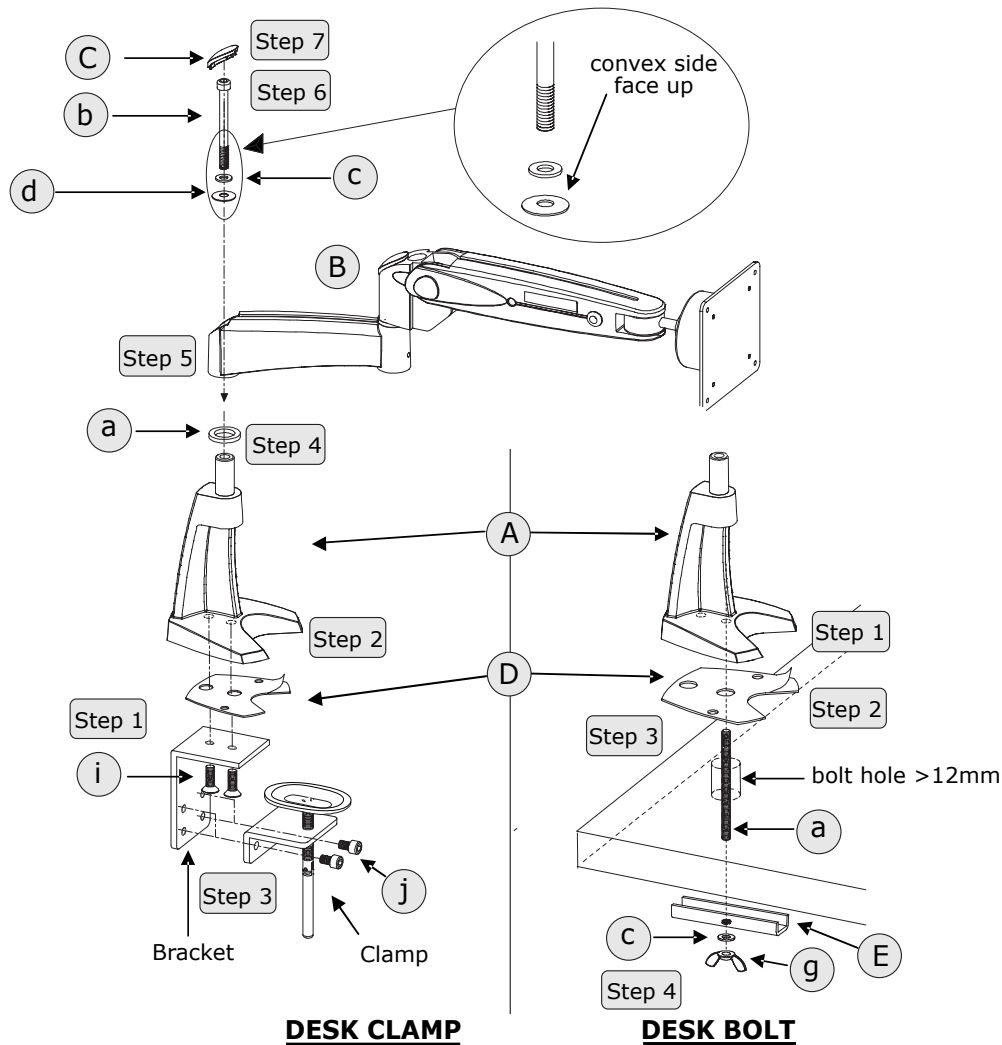

### Steps:

#### Clamp Mount:

- 1 Mount Bracket to Desk Base then tighten (i) Flat Head Cap Screw with (e) M5 Hex Wrench.
- 2 Attach (D) Base Cushion to (A) Desk Base.
- 3 Put Desk Base onto work surface then mount Clamp to the Bracket then tighten (j) Round Head Cap Screw with (e) M5 Hex Wrench.
- 4 Put (a) Plastic Spacer over (A) main shaft of Desk Base.
- 5 Put (B) Arm Assembly onto the main shaft.
- 6 Insert (b), (c) and (d) into Arm Assembly and tighten with (e) M5 Hex Wrench.
- 7 Snap (C) Plastic Cap into the top of Arm Assembly.

#### Grommet Mount:

- 1 Remove the Bracket from (A) Desk Base with (e) M5 Hex Wrench.
- 2 Attach (D) Base Cushion to (A) Desk Base.
- 3 Put Desk Base directly on the bolting hole of work surface and tighten (f) M8 Thread Rod with (h) M4 Hex Wrench.  
Insert (E) U Bracket & (c) Washer through (f) M8 Thread Rod and tighten them with (g) Wing Nut.
- 4 Follow Desk Mount Steps 4 to 7.

# **ERGOMART**

Ergonomic solutions for office and light industrial work environments

# SAA2321 LCD Arm Assembly Instructions

www.ergomart.com | 888 420 3200

LCD Monitor Attachment

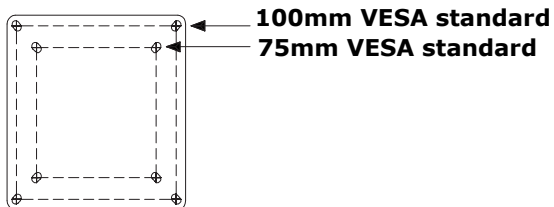
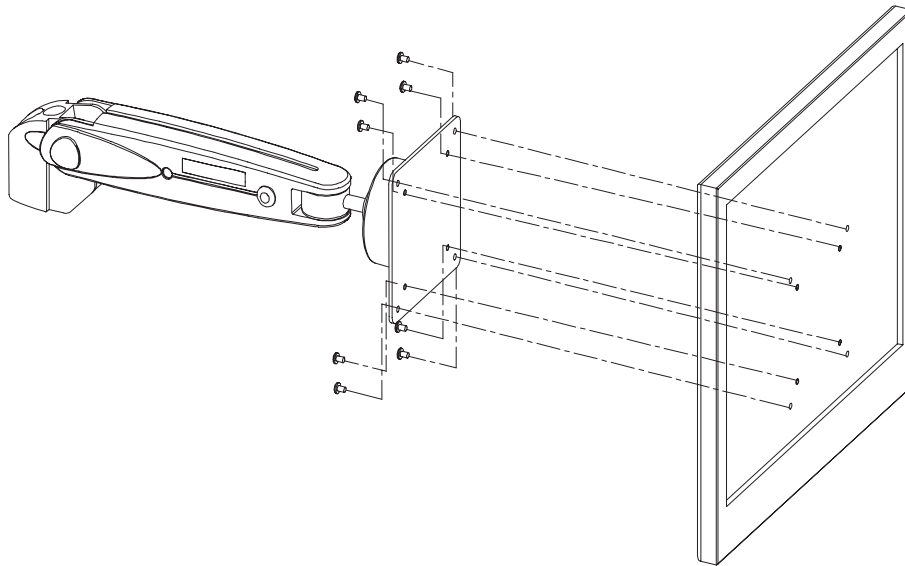

The combination 75/100mm VESA plate is pre-mounted to the SAA2321 LCD Arm

Mount the LCD monitor directly to the front plate of the Ball Joint Pivot with the supplied M4 x 6mm (or M4 x 10mm) screws or screws provided by the manufacturer. For 100mm x 100mm or 75mm x 75mm standard, use the 4 outer corner holes or 4 inner corner holes on the front plate respectively.

If the mounting area on your monitor is smaller than the 100mm VESA connecting plate and is recessed, remove the plate and replace it with the smaller 75mm plate. Then attach the plate to the back of the monitor.

## **IMPORTANT**

It is strongly recommended to use the mounting screws provided by the LCD monitor manufacturer. Due to the varieties of monitor mounting design, the mounting holes at the back of the LCD monitor might not be suitable for the M4 screws provided by our product. Using unsuitable mounting screws might cause damage to the LCD monitor. Please consult your LCD monitor manufacturer if you have enquires.

# ***ERGOMART***

*Ergonomic solutions for office and light industrial work environments*

# SAA2321 LCD Arm Assembly Instructions

www.ergomart.com | 888 420 3200

## Cable Management

### FOREARM

Thread monitor cable through Cable Mount located on underside of Forearm.

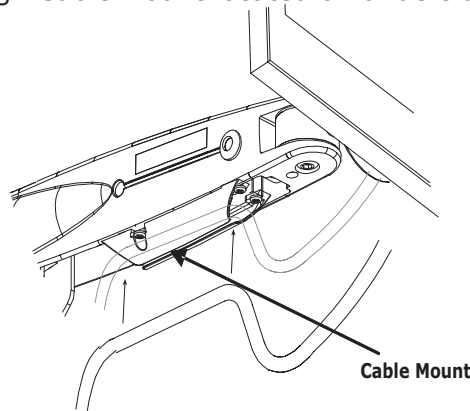

### EXTENSION

Attach 4" x 2.5mm Cable Ties to under side of Extension and around monitor cable(s). Secure Cable Ties, leaving slack for monitor cables to move freely.

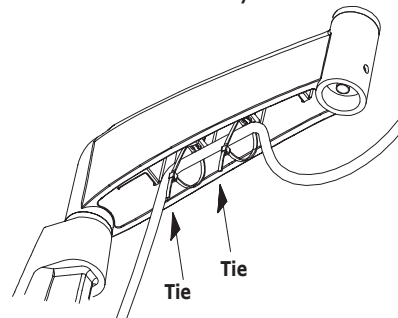

### DESK BASE

Attach 4" x 2.5mm Cable Ties to under side of Extension and around monitor cable(s). Secure Cable Ties, leaving slack for monitor cables to move freely.

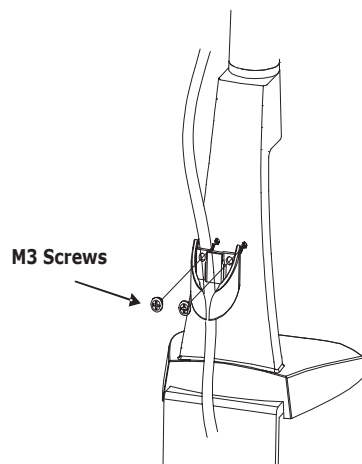

### **Note:**

To allow free movement of monitor and Arm/Extension, please leave sufficient slack in the cable(s).

# **ERGOMART**

*Ergonomic solutions for office and light industrial work environments*

# SAA2321 LCD Arm Assembly Instructions

www.ergomart.com | 888 420 3200

## Arm Adjustment

### Adjust the Ball-Joint for Tilt Action

Depending on the weight of the LCD monitor, adjustments may be required to the ball joint mechanism. If the monitor doesn't hold its position or is too tight, adjust the four tensioning screws located around the ball joint cover (clockwise to tighten, counter-clockwise to loosen). Check the monitor, and then adjust again if necessary.

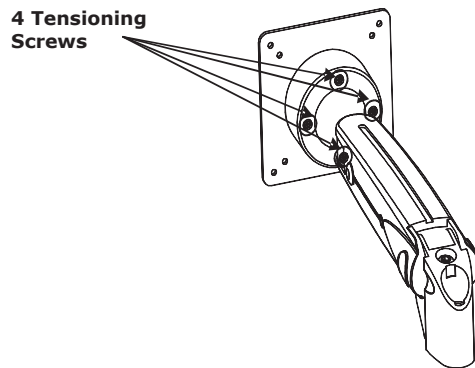

### Vertical Movement

Depending on the weight of the monitor, adjustments may be required to the Arm, this can be done by using the M5 Hex wrench provided.

If the Arm tends to drift down or rise up when positioned, it will be necessary to make small adjustments at the Adjustment Screw. The above shows the adjusting method. The M5 Hex wrench provided should be used to make this adjustment.

If the Arm tends to rise, the M5 Hex Wrench should be turned clockwise to decrease the tension until the Arm reaches a stable position.

If the Arm tends to fall, the M5 Hex Wrench should be turned counter-clockwise to increase the tension until the Arm reaches a stable position.

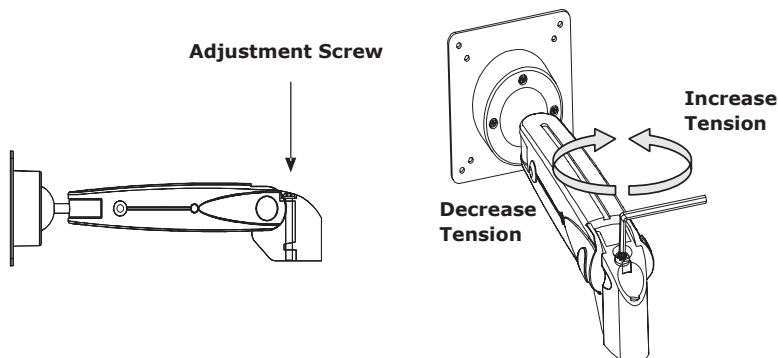

### Important

When performing this adjustment, the Arm must be in a HORIZONTAL position as shown above. To prevent damage to the aluminium Arm body, remove the M5 Hex Wrench before releasing the Arm from the horizontal adjustment position.

# **ERGOMART**

*Ergonomic solutions for office and light industrial work environments*

# SAA2321 LCD Arm Assembly Instructions

www.ergomart.com | 888 420 3200

Desk Base Template

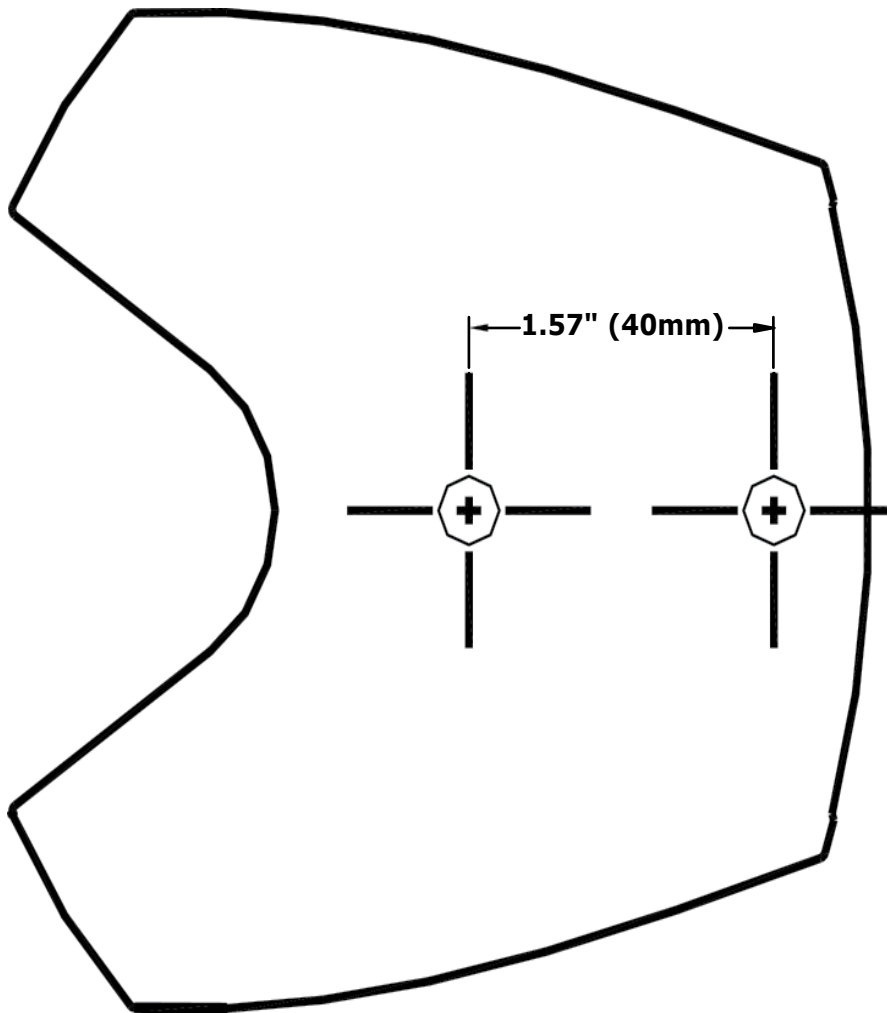

**ERGOMART**

*Ergonomic solutions for office and light industrial work environments*