

REVISIONS				
ZONE	REV	DESCRIPTION	DATE	APPROVED

SECTION A-A
SCALE 1 : 6

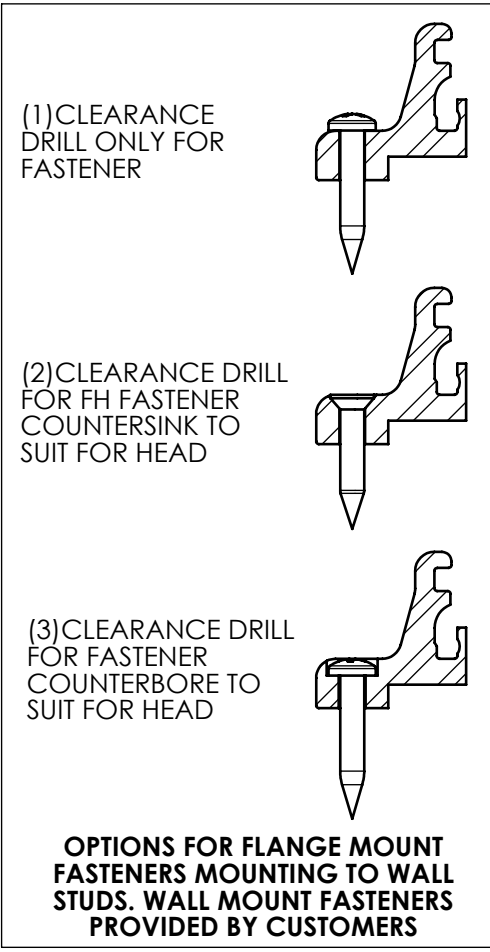

***NOTE:**
(1) WHERE ALLOWED BY CODE, USE A RECESSED STYLE DUPLEX RECEPTACLE SUCH AS A LEVITON #689. SOME INSTALLATIONS WILL REQUIRE A FLUSH MOUNTED DUPLEX RECEPTACLE. ACCOMMODATE SUCH CONFIGURATIONS WITH LOW PROFILE COMPUTER POWER PLUGS.

UNLESS OTHERWISE SPECIFIED:		NAME	DATE	<p>ERGOMART</p> <p>TITLE: EC TRACK - 51" BACKER BOARD MOUNTING CONFIGURATION</p>
DIMENSIONS ARE IN INCHES		DRAWN	R.NEAL 11/30/10	
TOLERANCES:		CHECKED	B.PACE	
ANGULAR: ± 1°		Q.A.		
ONE PLACE DECIMAL: ±0.1		MFG APPR.		
TWO PLACE DECIMAL: ±0.02		APPROVED	B.C.C.	SIZE
THREE PLACE DECIMAL: ±0.010		COMMENTS:		DWG. NO.
MATERIAL				REV
FINISH				B
DO NOT SCALE DRAWING				EGT
SCALE:				SHEET 1 OF 1