

REVISIONS				
ZONE	REV	DESCRIPTION	DATE	APPROVED

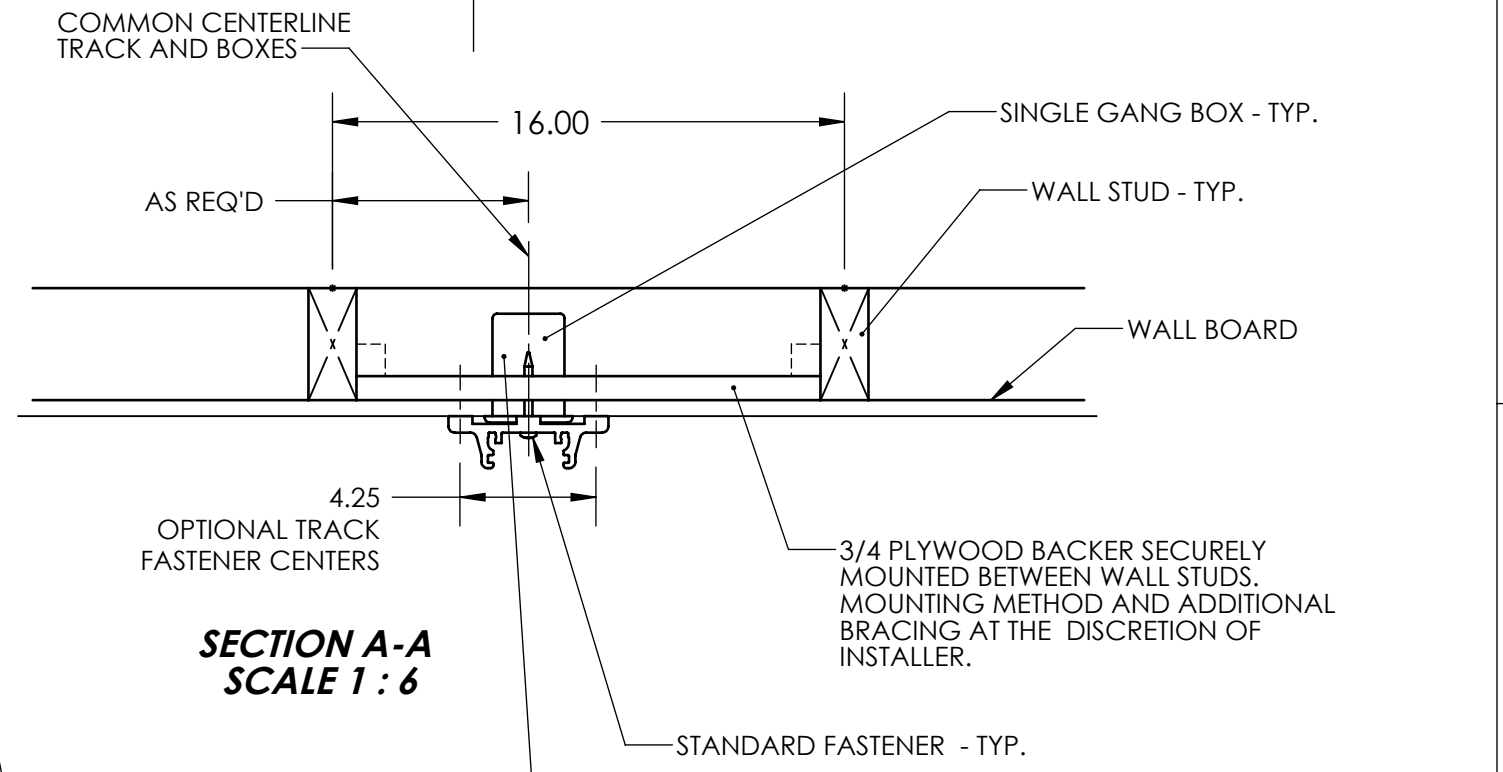

WIRING CAUTION
 THE BACKER MOUNTING METHOD FOR EC TRACK UTILIZES FASTENERS LOCATED ALONG THE CENTER OF THE TRACK. TO AVOID FASTENER CONTACT WITH WIRING, POSITION ELECTRICAL AND OTHER WIRING SO THAT SERVICE DOES NOT RUN VERTICALLY FROM BOX CENTER TO BOX CENTER.

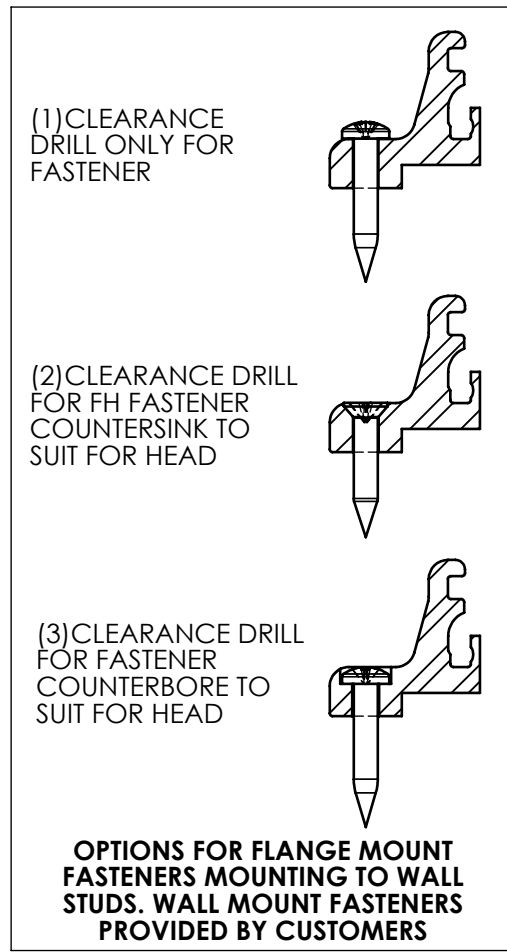

*** NOTE:**
 (1) WHERE ALLOWED BY CODE, USE A RECESSED STYLE DUPLES RECEPTACLE SUCH AS A LEVITON #689. SOME INSTALLATIONS WILL REQUIRE A FLUSH MOUNTED DUPLES RECEPTACLE. ACCOMODATE SUCH CONFIGURATIONS WITH LOW PROFILE COMPUTER POWER PLUGS.

UNLESS OTHERWISE SPECIFIED:		NAME	DATE	ERGOMART TITLE: EC TRACK - 78" BACKER BOARD MOUNTING CONFIGURATION
DIMENSIONS ARE IN INCHES		DRAWN	R.NEAL 11/1/10	
TOLERANCES: ANGULAR: ± 1° ONE PLACE DECIMAL: ±0.1 TWO PLACE DECIMAL: ±0.02 THREE PLACE DECIMAL: ±0.010		CHECKED	B.PACE	
MATERIAL		Q.A.		
FINISH		MFG APPR.		
DO NOT SCALE DRAWING		APPROVED	B.C.C.	SIZE DWG. NO. REV B EGT
COMMENTS:			SCALE:	SHEET 1 OF 1