

PM80 HEAVY DUTY MONITOR POLE MOUNT Installation Instructions

www.ergomart.com | 888 420 3200

1

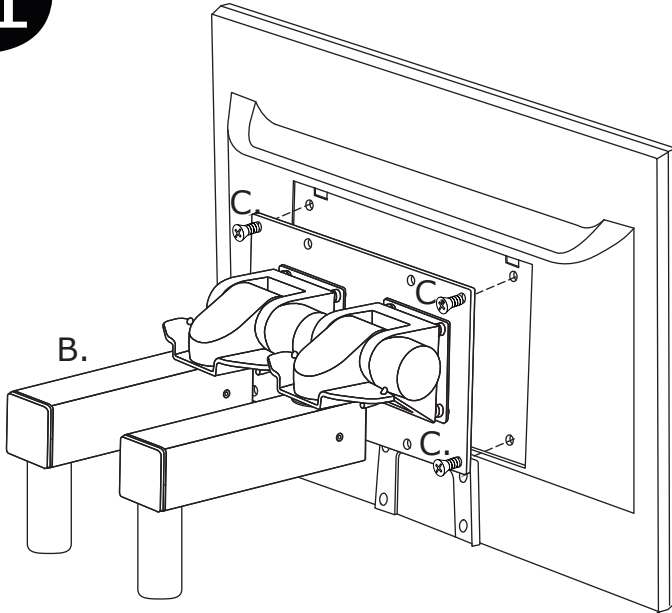

Attach VESA plate to monitor using Phillips pan head screws (C).

2

Nominal Diameter of Pole	Bushing Insert Pad
1.5"	Insert Ribbed (I)
1.75"	Insert Smooth (H)
1.9"	Pre-installed Pad
2"	No Bushing Required

Use chart to select the proper bushing for the pole's diameter. Mount comes with easy to remove pad insert, ready for 1.9 inch poles and the Ergomart series 192 pole.

3

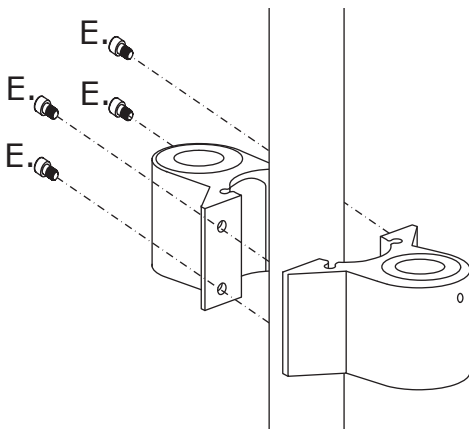

With the proper bushing or insert in place, attach the mount to the pole using a 3/16" Allen wrench and four 1/4-20x1/2" screws (E). To ensure a proper fit, first install all 4 screws without over tightening. Then gradually tighten each screw a little at a time, moving from one screw to the next to keep the pressure relatively even.

4

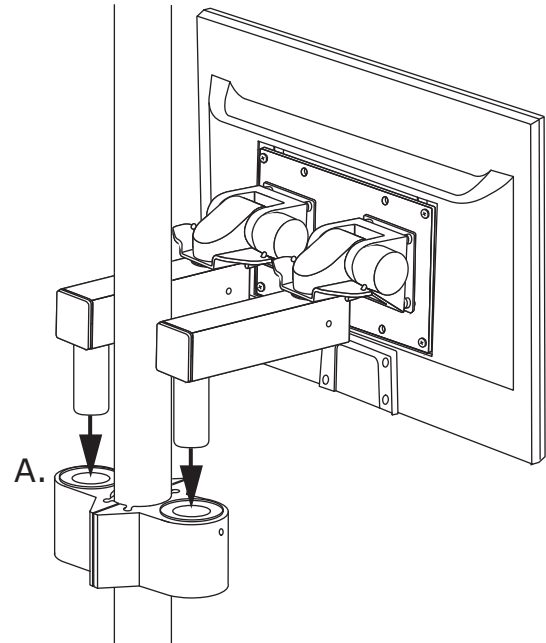

Place each arm into the Kit J.

ERGOMART







Ergonomic solutions for office and light industrial work environments

©2014 Ergomart. All rights reserved.

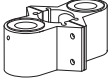
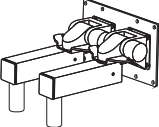
PM80 HEAVY DUTY MONITOR POLE MOUNT

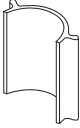
Parts List

www.ergomart.com | 888 420 3200

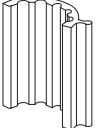
ITEM	DESCRIPTION/ PART NO.	QUANTITY
Hardware Included		
A	 PM80 Heavy Duty Monitor Pole Mount	1
B	 2 4.5" Arms, 2 Tilterheads, 1 VESA plate (pre-assembled)	1
C	 M4-12 Phillips Pan Head Screw	4
D	 Bushing	2
E	 1/4-20 x 1/2" Screw	4
F	 3/16" Allen Wrench	1
G	 Foam Pad	1
H	 Smooth Insert	1
I	 Ribbed Insert	1

ERGOMART

Ergonomic solutions for office and light industrial work environments

©2014 Ergomart. All rights reserved.